

CARNES COMPANY, 448 S. Main St., P. O. Box 930040, Verona, WI 53593-0040 Phone: (608)845-6411 Fax: (608)845-6504 carnes@carnes.com

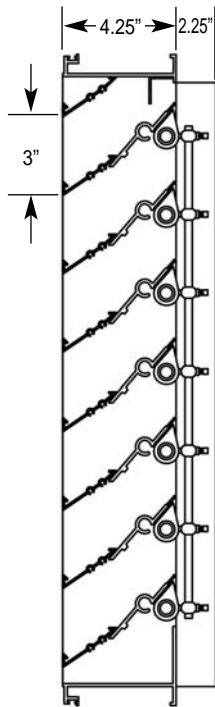

Section View

### Model FPJB Standard Specifications

**Frame:** .081 extruded aluminum, 4.25" deep

**Adjustable Blade:** .125 extruded aluminum

**Fixed Blade:** .081 extruded aluminum positioned on a 37° angle on approximately 3.0" centers

**Finish:** mill aluminum (standard)

**Screen:** 3/4" x .051" flattened aluminum in removable frame. Screen is mounted as standard on inside (rear) as looking from exterior of building.

**Maximum Panel Size:** 60"w x 120"h single section. Factory assembled multi-section max: 96"w x 120"h. Larger sizes are field assembled.

**Minimum Panel Size:** 12"w x 12"h

**Note:** Drainable blade louvers should be limited to 10' maximum section widths (no more than 10' between vertical downspouts) to enable the drainable design to function effectively.

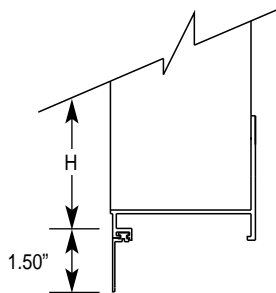
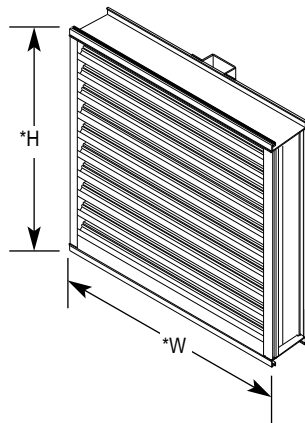

Flanged Frame  
Optional

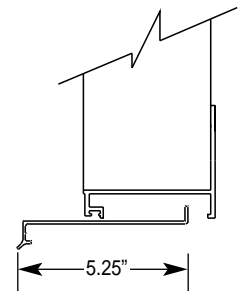

Extended Sill  
Optional

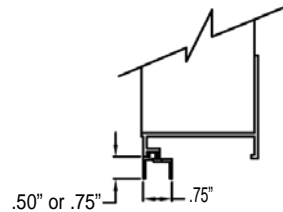

Glazing Adapter  
Optional

\*Width and height dimensions are approximately 1/4" under listed size.

Tag	Qty.	Size		Frame	Variations
		Width	Height		

**Project**  
**Arch./Engr.**  
**Representative**

**Location**  
**Contractor**  
**Date**

## Free Area in Square Feet

HEIGHT INCHES	WIDTH IN INCHES								
	12	18	24	30	36	42	48	54	60
12	0.49	0.73	0.98	1.22	1.47	1.71	1.96	2.20	2.45
18	0.73	1.10	1.47	1.84	2.20	2.57	2.94	3.30	3.67
24	0.98	1.47	1.96	2.45	2.94	3.43	3.92	4.41	4.90
30	1.22	1.84	2.45	3.06	3.67	4.28	4.90	5.51	6.12
36	1.47	2.20	2.94	3.67	4.41	5.14	5.88	6.61	7.34
42	1.71	2.57	3.43	4.28	5.14	6.00	6.85	7.71	8.57
48	1.96	2.94	3.92	4.90	5.88	6.85	7.83	8.81	9.79
54	2.20	3.30	4.41	5.51	6.61	7.71	8.81	9.91	11.02
60	2.45	3.67	4.90	6.12	7.34	8.57	9.79	11.02	12.24
66	2.69	4.04	5.39	6.73	8.08	9.42	10.77	12.12	13.46
72	2.94	4.41	5.88	7.34	8.81	10.28	11.75	13.22	14.69

## FPJB Selection and Examples

### Example 1:

Airflow given as 10,000 cfm – select louver size.

A. Determine louver free area by dividing airflow by free area velocity (do not exceed 1250 fpm on intake louver application).

$$10,000 \text{ cfm} \div 1250 \text{ fpm} = 8.0 \text{ sq. ft.}$$

Airflow            F.A.V.            Req'd Louver Free Area

B. Select a louver with at least the required louver free area from the Free Area Chart above.

48" w x 54" h

8.81 ft. free area

1135 fpm free area velocity (10,000) cfm  $\div$  8.81 sq. ft. F.A.V.

(Other selections available - see Free Area Chart above.)

### Example 2:

Louver size given 42" w x 72" h intake - determine maximum airflow.

A. Use Free Area Chart to determine.

$$\text{Free Area} = 10.28 \text{ sq. ft.}$$

B. Free Area x Free Area Velocity (do not exceed 1250 fpm on intake louver applications).

$$10.28 \text{ sq. ft.} \times 1250 \text{ fpm} = 12,850 \text{ cfm}$$

Free Area            F.A.V.            Max. Airflow