

RSPA41

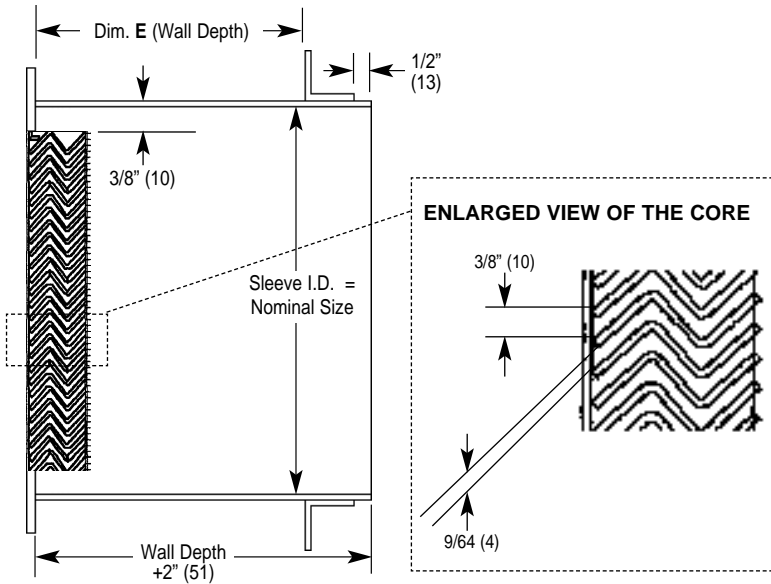

RSPA42

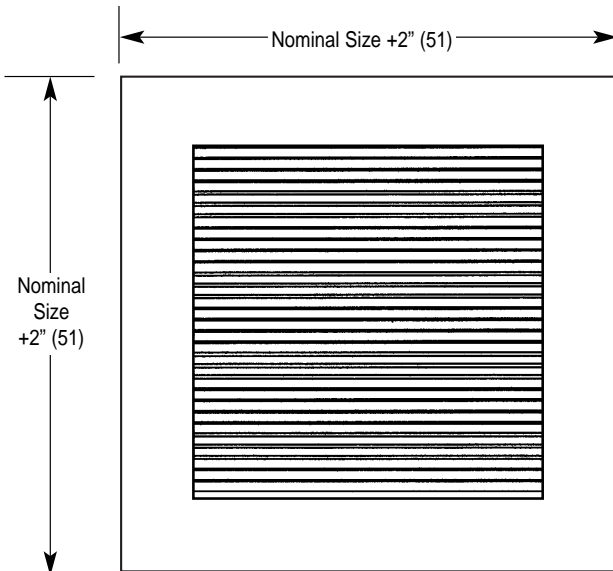
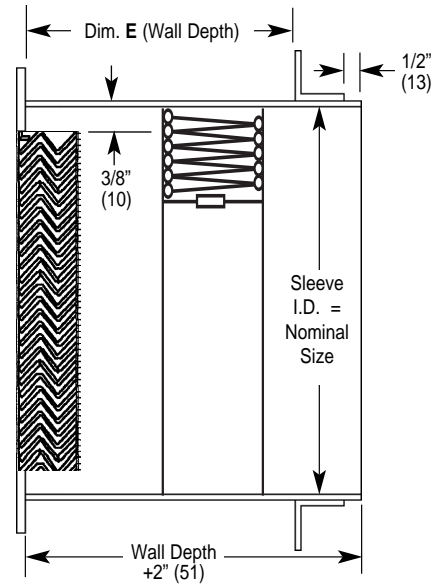

Notes:

- Recommended wall opening size is listed size plus 3/4" (19).
- Standard finish is electrocoat acrylic baked enamel.
- Standard color is #11 Bright White.
- Metric dimensions are given in millimeters.
- Because of the special application for this product, there is a definite "up" when mounting this in a side wall.
- Fire damper on model RSPA42 is UL555 classified with 1-1/2 hour rating.
- Fire damper is dynamic wall mount style as shown.
- Minimum wall thickness for RSPA42 is 8" (203) to conform to UL requirements.

Notes on Construction:

1. Sleeve and Face are constructed of 12 gauge hot rolled steel.
2. Wall Angles are 1-1/2" x 1-1/2" x 1/8" (38 x 38 x 3) hot rolled steel. They are shipped in 4 pieces for field welding.
3. Core consists of:
 - 12 gauge hot rolled steel louvers formed with 90° angles to created "Z" shape.
 - Louvers are installed on 3"/8" (10) centers, which provide a labyrinth to deter passage of a rope, twine or string.

DISCLAIMER: ASX Suicide Deterrent Grilles are designed to reduce the potential risk of suicide attempts and are designed to allow air flow through them to provide adequate ventilation to the space where used according to specifications. These products do not guarantee that they are suicide proof or that they cannot be used to inflict harm. ASX warrants only the construction and performance in accordance to the specific specifications of the units as listed in its appropriate specification sheet.