

Imperial [IP] Dimensions
Metric (SI) in Parentheses

Air Specialties Express, 448 S. Main St., P. O. Box 930040, Verona, WI 53593-0040 Phone: (877)945-9175 Fax: (608)845-6504 www.airspecialties.com

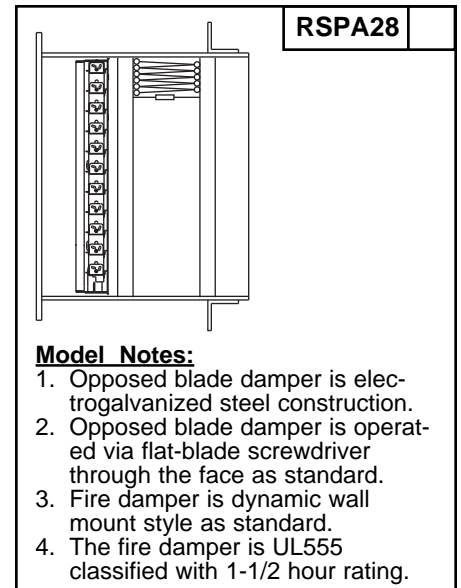
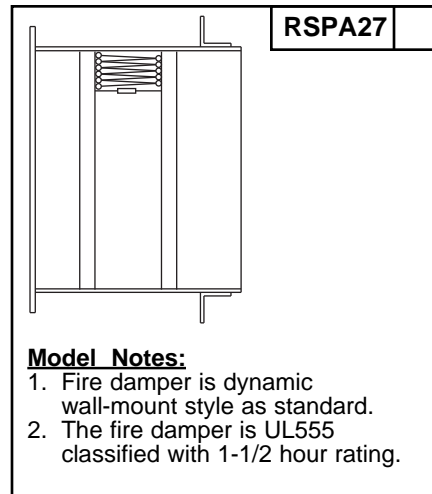
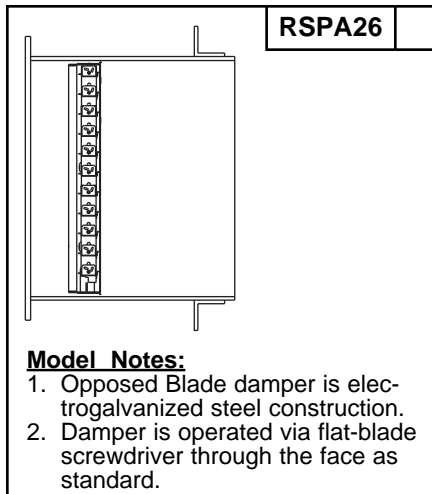
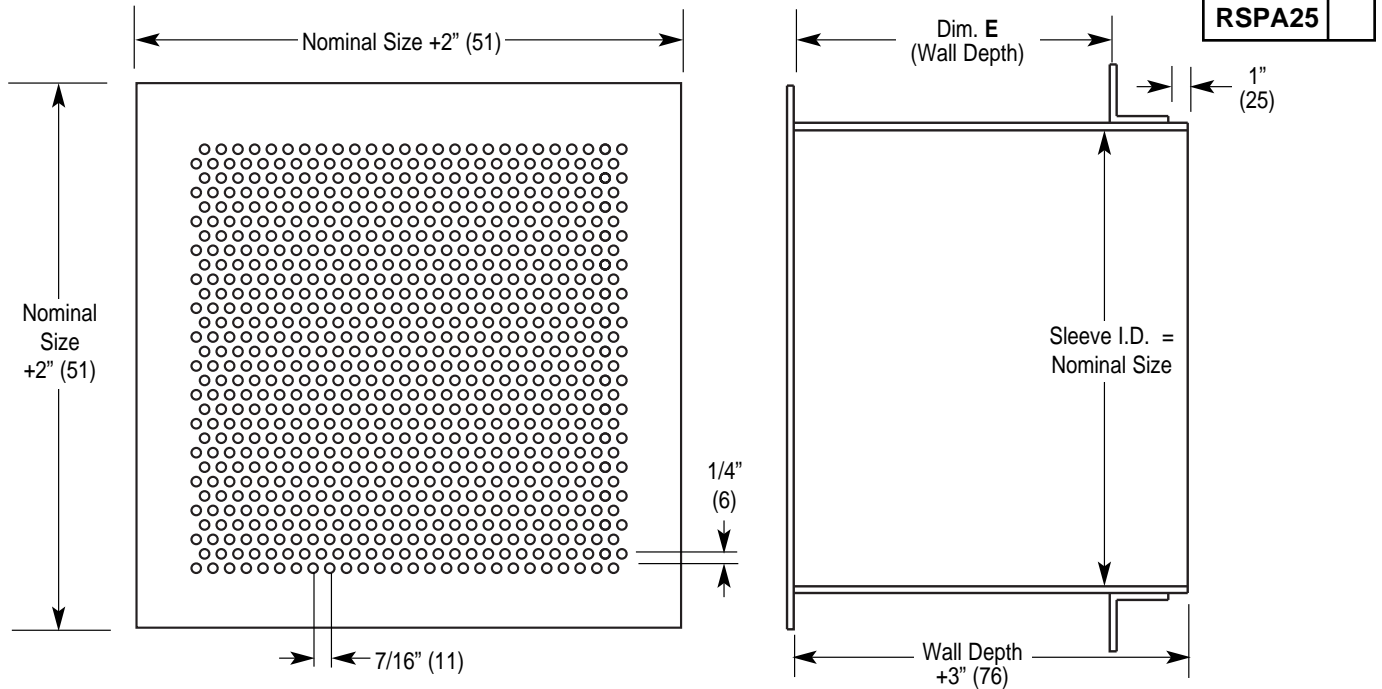

Overall Notes:

1. Metric dimensions are given in millimeters.
2. Standard finish is electrocoat acrylic baked enamel.
3. Standard color is #11 Bright White.
4. Recommended Minimum Wall Opening size is Listed Size Plus 3/4" (19).
5. Size 12" x 12" (305 x 305) with an 8" (203) wall depth, is shown above.

Construction Notes:

1. Face is 3/16" hot rolled steel, with 1/4" (6) diameter holes on staggered 7/16" (11) centers.
2. Sleeve is constructed of 3/16" hot rolled steel.
3. Wall Angles are 2" x 2" x 3/16" (51 x 51 x 5) hot rolled steel. They are shipped in 4 pieces for field welding.