

Imperial [IP] Dimensions
Metric (SI) in Parentheses

Air Specialties Express, 448 S. Main St., P. O. Box 930040, Verona, WI 53593-0040 Phone: (877)945-9175 Fax: (608)845-6504 www.airspecialties.com

SECURITY PRODUCTS

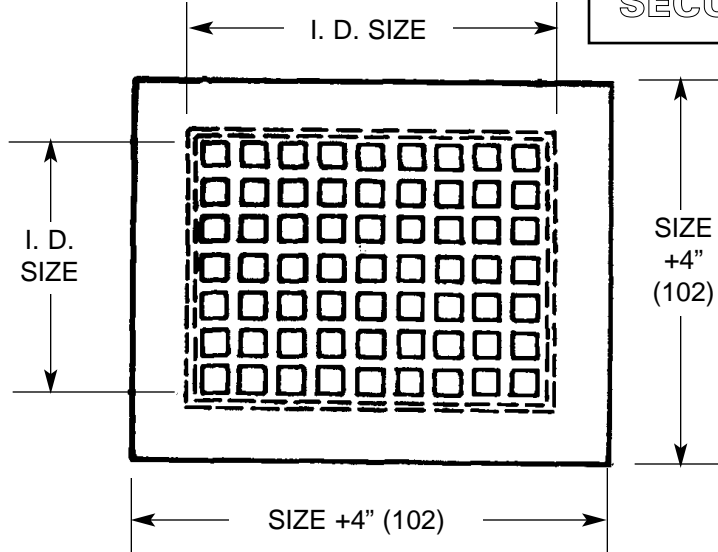

MODEL RSPA 03

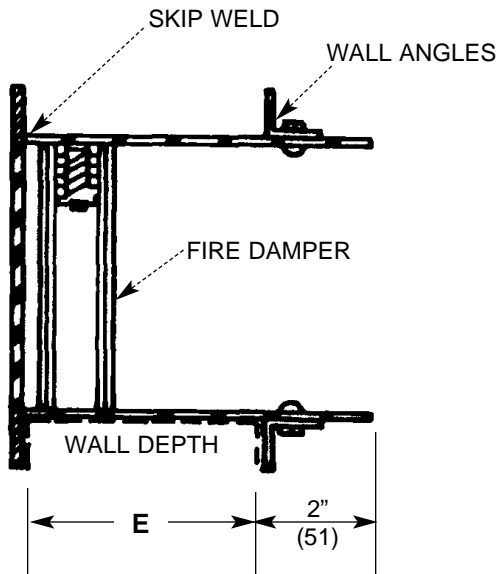

MODEL RSPA 04

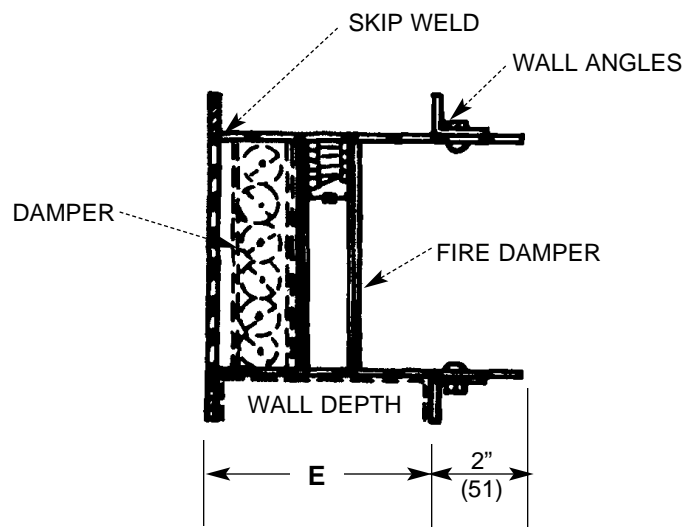

STANDARDS:

1. **Face Plate:** 12 gauge hot rolled steel, hole size 1/2" (13) square on 11/16" centers. 45% Free Area.
2. **Sleeve:** 12 gauge hot rolled steel.
3. **Angles:** 1-1/2"x1-1/2"x1/8" (38x38x3) hot rolled steel with mounting holes for 1/4" (6) security bolts at 6" (152) O. C. max., angles furnished loose for field installation.
4. **Security Bolts:** 1/4" (6) spanner head type.
5. **Fire Damper:** Galvanized steel frame and interlocking blades with 212°F (100°C) fusible link standard. Fire damper is U. L. Listed.
6. **Finish:** White Prime Coat.

OPTIONS

1. Angles furnished without mounting holes, for field welding to sleeve.
2. Angles furnished welded to sleeve.
3. Fire damper available with 165°F (4°C) fusible link.