

TOP SECTION

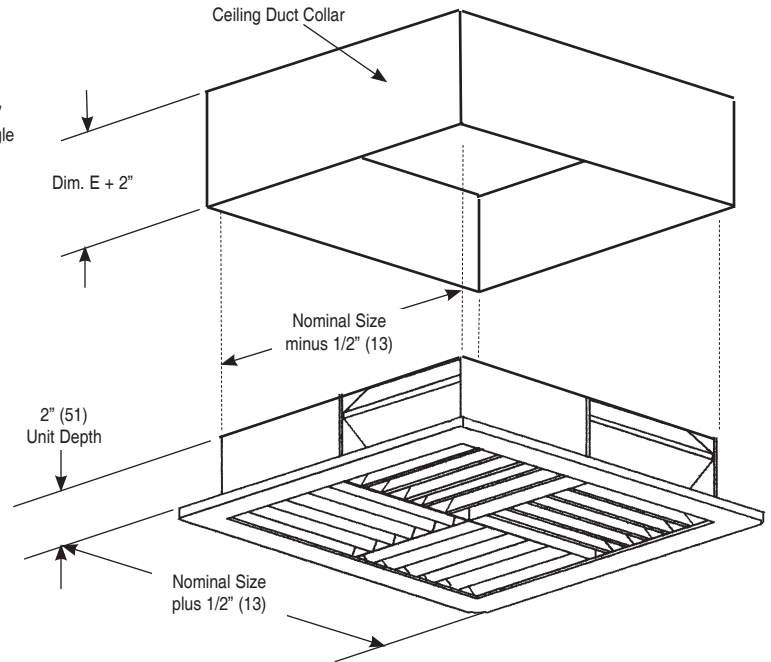

THROW PATTERNS

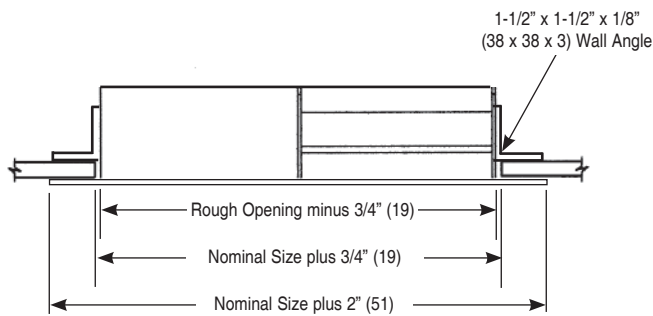
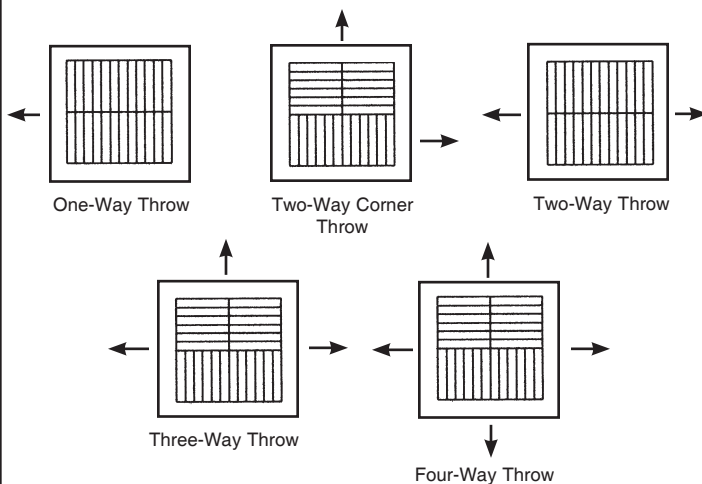

Notes:

- Recommended wall opening size is nominal size plus 3/4" (19).
- Standard finish is electrocoat acrylic baked enamel.
- Standard color is #11 Bright White.
- Metric dimensions are given in millimeters.
- Dimension E is the ceiling depth.

Notes on Construction:

1. Sleeve and Face are constructed of 12 gauge hot rolled steel.
2. Wall angles are 1-1/2" x 1-1/2" x 1/8" (38 x 38 x 3) hot rolled steel. They are shipped in four pieces for field welding or mounted with taper proof screws.
3. Unit consists of four cores continuously welded to the face plate with a welded one piece sheave that fits over the core and attaches to the duct sleeve. Individual cores shall be enclosed by shroud.
4. Core consists of:
 - 12 gauge hot rolled steel louvers with 90° angles to create a "Z" shape.
 - Louvers are installed on 3/8" (10) centers, which provide a labyrinth to deter passage of rope, twine or string.