

Imperial [IP] Dimensions
Metric (SI) in Parentheses

CARNES COMPANY 448 S. Main St., P. O. Box 930040, Verona, WI 53593-0040 Phone: (608)845-6411 Fax: (608)845-6504 www.carnes.com

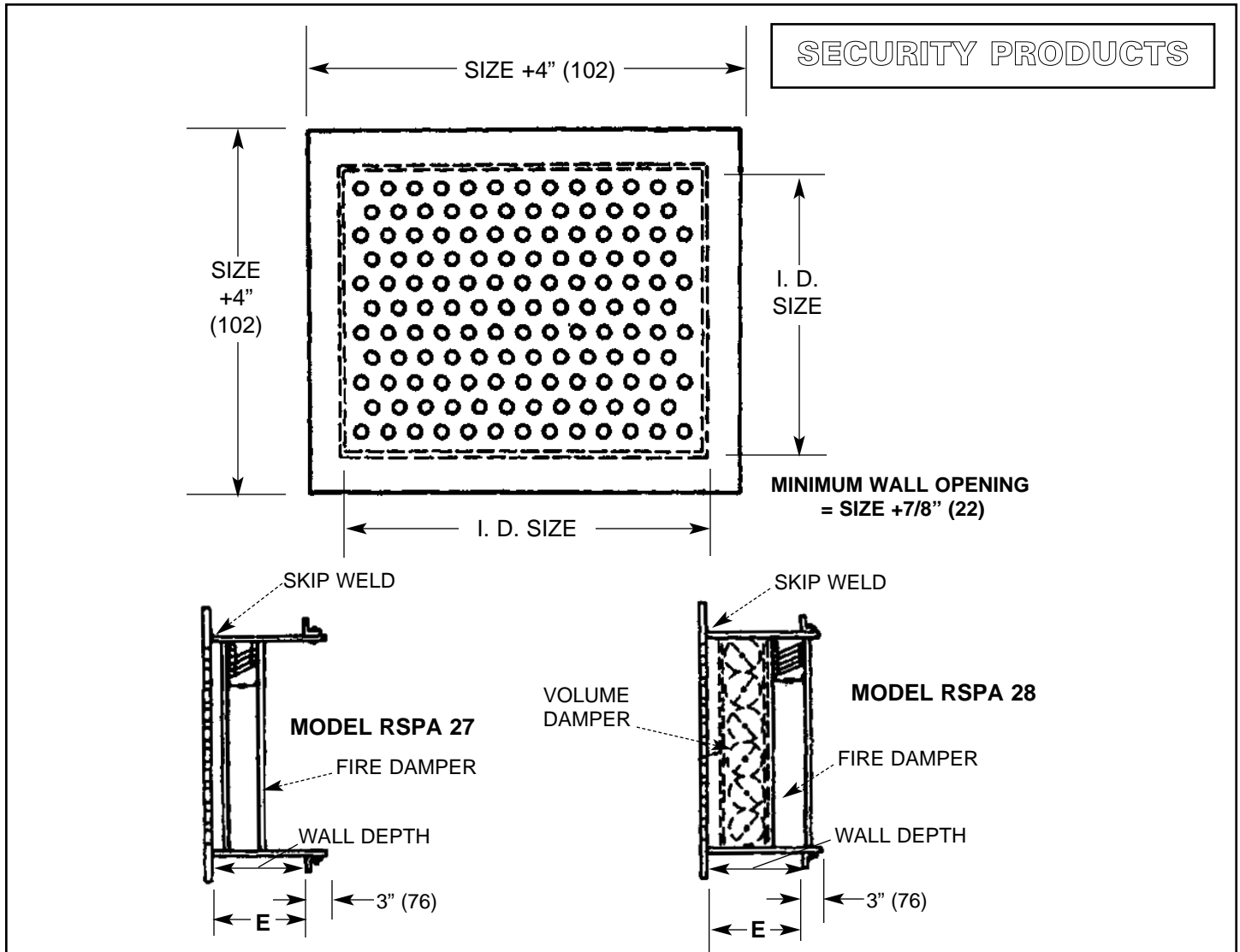

STANDARD:

1. **Face Plate:** 3/16" (5) thick hot rolled steel. Hole size 1/4" (6) diameter on 7/16" (11) centers.
2. **Sleeve:** 3/16" (5) thick hot rolled steel.
3. **Angles:** 2" x 2" x 3/16" (51 x 51 x 5) hot rolled steel with mounting holes for 1/4" (6) security bolts at 6" (152) max. Angles furnished loose for field installation.
4. **Security Bolts:** 1/4" (6) spanner head type.
5. **Damper:** Balancing opposed blade damper, adjustable for volume of air. Front operated.
6. **Fire Damper:** Galvanized steel frame and interlocking blades with 212°F (100°C) fusible link.
7. **Finish:** White Prime Coat.

OPTIONS:

1. Angles furnished without mounting holes for welding to sleeve.
2. Damper with 160°F (74°C) fusible link.