

Imperial [IP] Dimensions
Metric (SI) in Parentheses

Extruded Aluminum Linear Registers and Grilles
Removable Core for Sill and Floor Application [1/8" (3) Bars on 1/4" (6) Centers]

CARNES COMPANY 448 S. Main St., P. O. Box 930040, Verona, WI 53593-0040 Phone: (608)845-6411 Fax: (608)845-6504 www.carnes.com

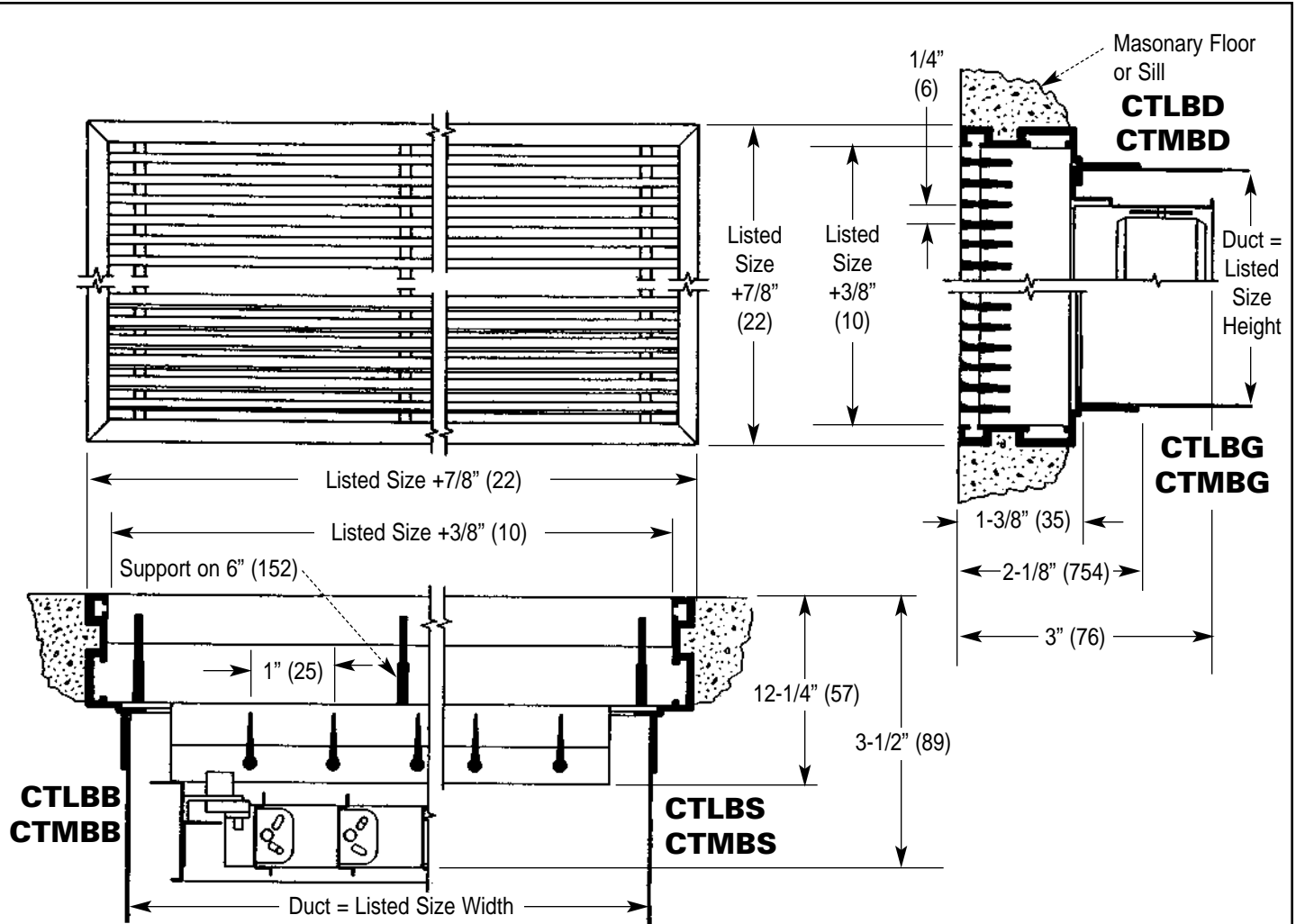

DIMENSIONS LISTED IN INCHES (Millimeters)

Model	Degree Blade Deflection	Damper	Straightening Vanes	Available Sizes In Inches (Millimeters)*			
				Listed Size Height		Listed Size Width	
				Min.	Max.	Min.	Max.
CTLBG	0°	NO	NO	2-1/2 (64)	12 (305)	6 (152)	72 (1829)
CTMBG	15°	NO	NO	2-1/2 (64)	12 (305)	6 (152)	72 (1829)
CTLBD	0°	YES	NO	2-1/2 (64)	12 (305)	6 (152)	72 (1829)
CTMBD	15°	YES	NO	2-1/2 (64)	12 (305)	6 (152)	72 (1829)
CTLBS	0°	NO	YES	2-1/2 (64)	12 (305)	6 (152)	72 (1829)
CTMBS	15°	NO	YES	2-1/2 (64)	12 (305)	6 (152)	72 (1829)
CTLBB	0°	YES	YES	2-1/2 (64)	12 (305)	6 (152)	72 (1829)
CTMBB	15°	YES	YES	2-1/2 (64)	12 (305)	6 (152)	72 (1829)

NOTES:

1. Single blade damper on size 2-1/2" (64).
2. Optional with blade supports on 3" (76) centers.
3. All ducts by others.
4. Standard finish is #26 sanded, etched and lacquer.

* Minimum and Maximum single unit sizes. Larger list widths furnished as separate pieces.